



QHC27M 27kW Heater Controller 3 Channel Standard (Manual)

Quick Start Guide & Instructions

QHC27M



QHC27M

Three Phase 415v / Three Zone / Manual Operation / Soft Start

Quick Start for QHC27M 27kW Heater Controller with Soft Start

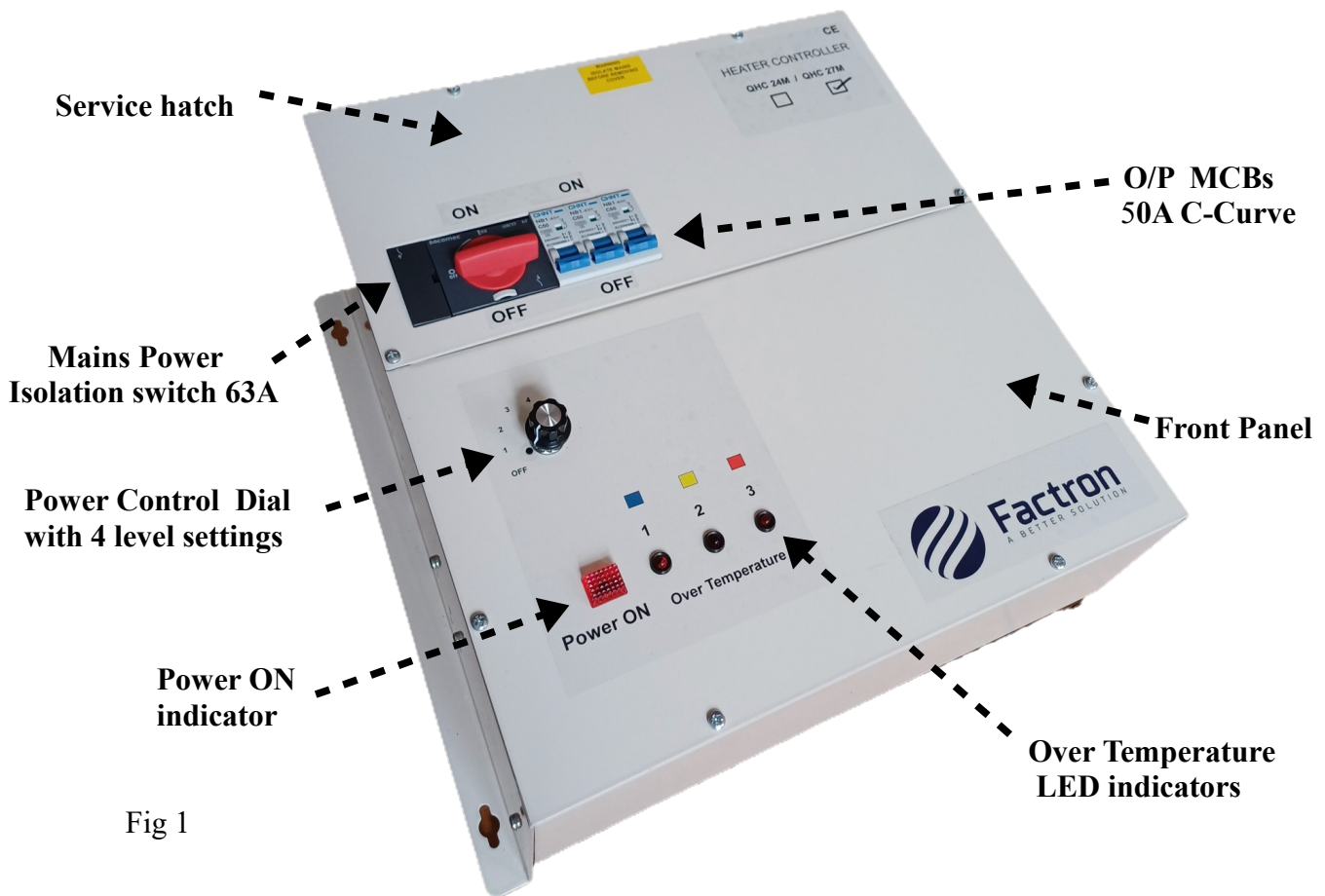

Fig 1

- 1) Start by removing the service hatch. Remove the 4 fixing screws, 2 at the top and 2 in the corners. There is a Din Rail revealed once the service hatch has been removed.
- 2) Use the cable grommets to bring the cables into and out of the controller base .
- 3) Connect the Mains IN as follows, Neutral blue wire to terminal #1 – **Neutral IN**, Live brown wire to terminal #2 – **L1 IN**, Live black wire to terminal #3 – **L2 IN**, Live grey wire to terminal #4 – **L3 IN**.
- 4) There are two methods on how to connect the Infrared Heaters to the controller.
 - a) Connect the heater or heaters Live to O/P1 terminal #5 **switched L1**, the O/P has a maximum load capacity of 9kW or 40amps. O/P1 can also be referred to as Zone 1. Connect the heater Neutrals to **Neutral Out** terminals #8 – 13. The heater Earth is connected to the **Earth** terminal #14. The remaining heaters should be distributed across the remaining two outputs O/P2 & O/P3. Please ensure that the **load is balanced across the output terminals #5 – 7**. See fig. 2 Specially when using Single phase heaters!
 - b) Connect to an external distribution box. Connect O/P1 to terminals marked **1**, O/P2 to terminals marked **2** and O/P3 to terminals marked **3**. Connect the Neutral OUT to the blue terminals marked **N**. Connect the Earth to the green/yellow **Earth** terminals. Then connect the heaters to the other side of the terminals to the appropriate connections. **Live** connections to terminals **1,2&3**. **Neutral** connections to blue terminals **N** and **Earth** connections to the **Earth** terminals. See fig. 3
- 5) When all connections are complete and connected correctly, check once again that the wiring is correct as per 3) & 4). Then replace the service hatch cover and tighten the fixing screws.

Remember to fit C-Curve MCB circuit breakers & a fused spur for each heater. Also note, single module Residual Current Devices should not be connected.

QHC27M 27kW Heater Controller Din Rail & Connections

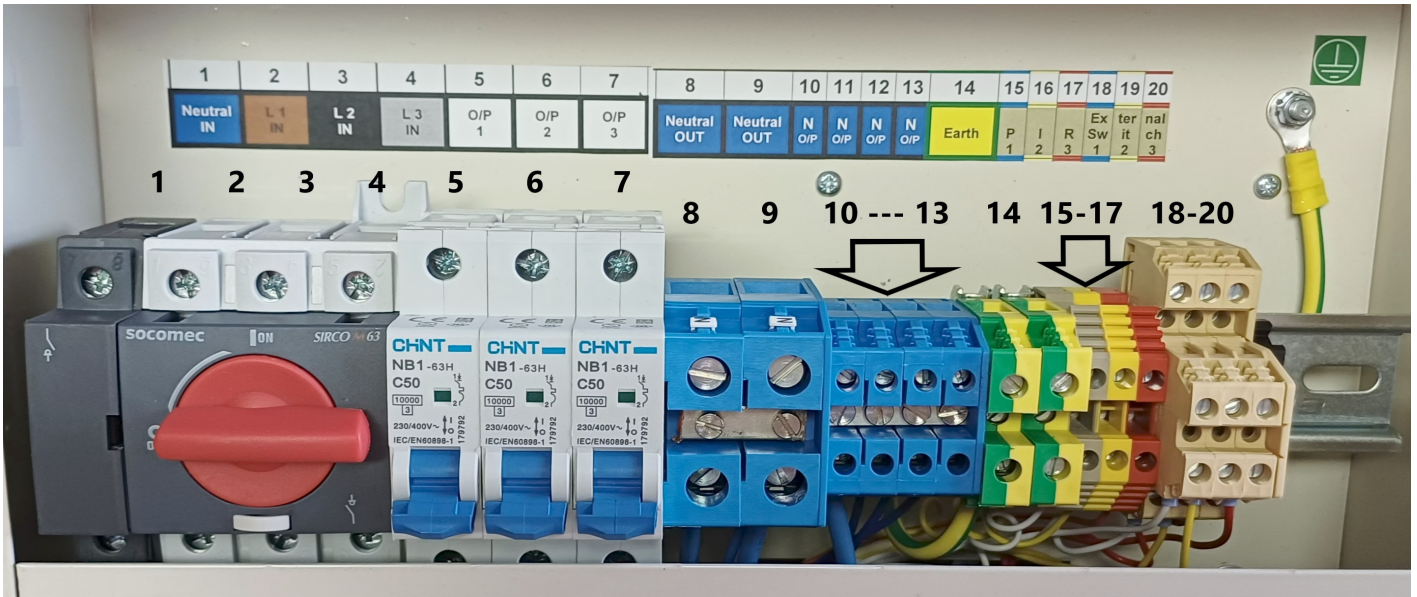

Fig 2

- 6) Turn ON or reconnect the Main Power to the controller. The red neon lamp on the front panel will illuminate to indicate that the unit is **LIVE**.
- 7) There are auxiliary devices such as mains operated PIR motion detectors. These can be connected to terminals #15 – 17. External push button switches N/O contacts which are voltage free can be connected to terminals #18 – 20. See fig's 6,7 & 8 page 4 also see fig's 9 & 10 page 5.
- 8) An optional auxiliary device QHVC-S3 External 3 zone variable control can be connected to terminals #21– 25. This device is hard wired to the controller and can be located 20 to 30 meters away.
- 9) Please note it is not recommended to connect individual Residual Current Devices (RCD's) to the controller.

Distribution Box

This item is sold separately P/No. QHDB18

- Terminals 1 – O/P1
- Terminals 2 – O/P2
- Terminals 3 – O/P3
- Terminals N – N out
- Terminals E – Earth

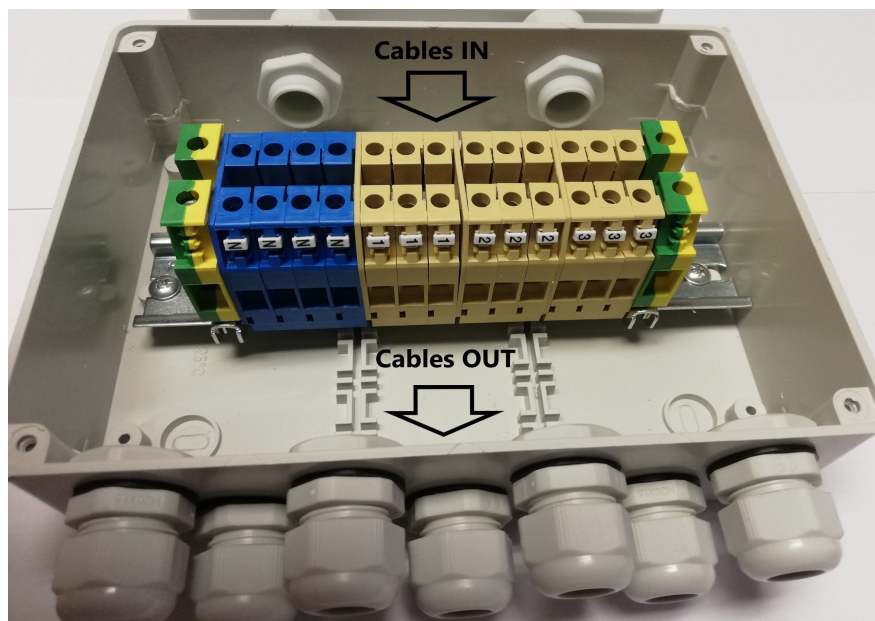

Fig 3

The cable connections required from the QHC27M to the Distribution Box are as follows, **Cables IN** Neutral x 1, Output 1 x 1, Output 2 x 1, Output 3 x 1 & Earth x 1. The wire size should be 6mm Square. **Cables OUT** as per heaters being connected to the distribution box.

Controller Setup Manual Operation S1 & S2

To access S1 & S2, remove both the service hatch & front panel.

S1 & S2 are found on the printed circuit board (PCB) QHPCB-A. There is a set on each board. See fig. 4

Default setting : Remote OFF – S1 Jumper is in the Off position pins 2 & 3, factory set.

PIR & External Switches OFF - S2 Slide switch is set in the Off position (select 2), factory set.

(Note: The remote setting is not available on models QHC18M, 24M or 27M, S1 is always set at Off)

Set up for use with PIR's & External Switches – S2 Slide switch must be set in the ON position (select 1)

See fig. 4

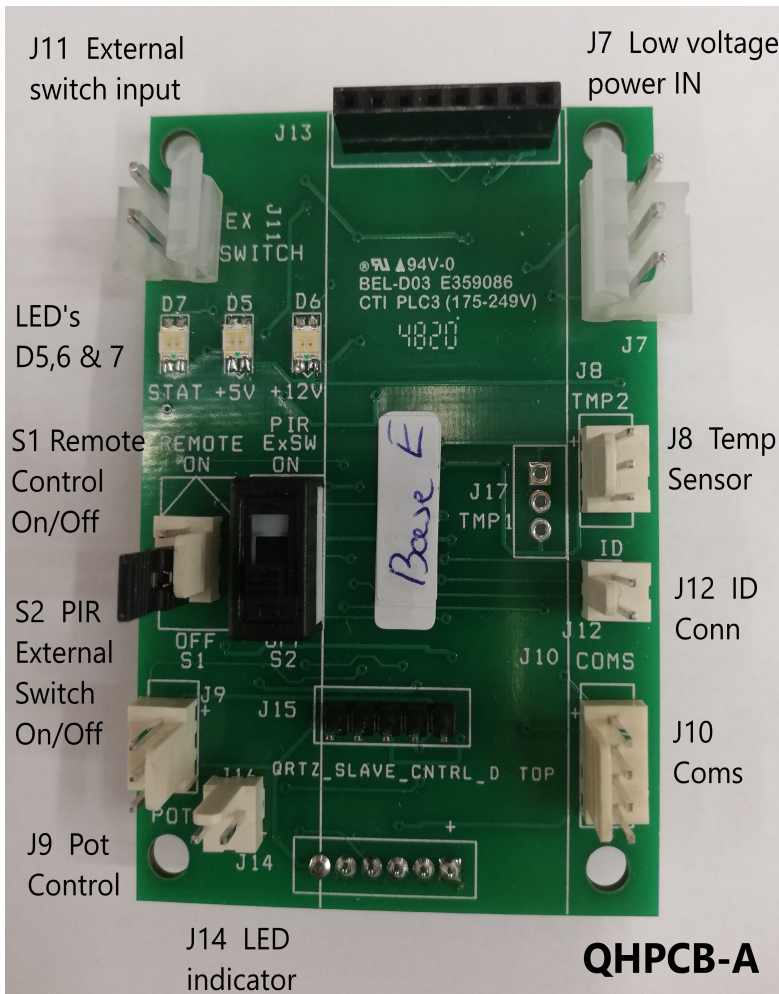

Fig 5

LED's D5,6 & 7 on the PCB

These are bi-colour LED's and indicate the status of the electronic board.

LED D7 marked STAT, will flash GREEN to indicate the board is running and the phase is detected. If the D7 LED was RED this indicates that the phase has not been detected and the board will not run.

LED's D5 (+5V) & D6 (+12V) are GREEN to indicate that the on board power supply +5v & +12v are both present and running. See fig. 5

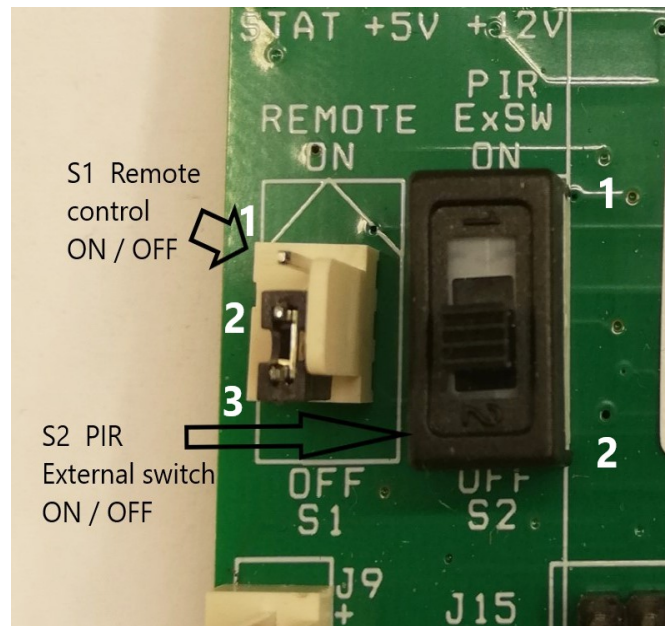

Fig 4 IMPORTANT note: In Manual mode S1 must be in the OFF position.

PIR Motion Detectors & (Programmable 7-Day Timers)*

Connection & Operation

PIR motion detectors are passive infrared sensors, an electronic device which is triggered by infrared light from the movement of objects in its field of view.

We recommend the QHPIR is used with our QHC controllers.

When using a PIR – S2 slide switch must be in the ON position (select 1). See fig. 4
Remember there are 3 zones, Blue Yellow & Red. Connect the Switched Live Out trigger L' to the PIR input terminal #15, 16 or 17 for separate control of each zone. Only 1 PIR per zone can be connected.
Blue zone = #15, Yellow zone = #16 & Red zone = #17. See fig's 6, 7 & 8.

For single PIR operation, a jumper link can be fitted connecting the 3 inputs (terminals 15,16 & 17) together. In this configuration **1 PIR** will turn ON all 3 zones together.

The **PIR** when triggered, will also trigger the controller and turn on the appropriate zone. The ON time will depend on the time set on the PIR. This is found on the underside of the PIR housing.
Note: **PIR** ON time is adjustable from 5 seconds to 15 minutes.

Note: a PIR should not be located directly in front of an Infrared heater. The infrared light emitted from the heater will keep the PIR permanently triggered and the motion detector will fail.

Please follow the instructions provided with the PIR (QHPIR) for installation and connection.

* Programmable Timers can also be connected to the controller via the terminal inputs 15 to 17 see fig 8.

These inputs must be linked together in order for the Programmable Timer to function correctly.

Remember to follow the Programmable Timer instructions when connecting its output to terminal inputs 15,16 & 17.

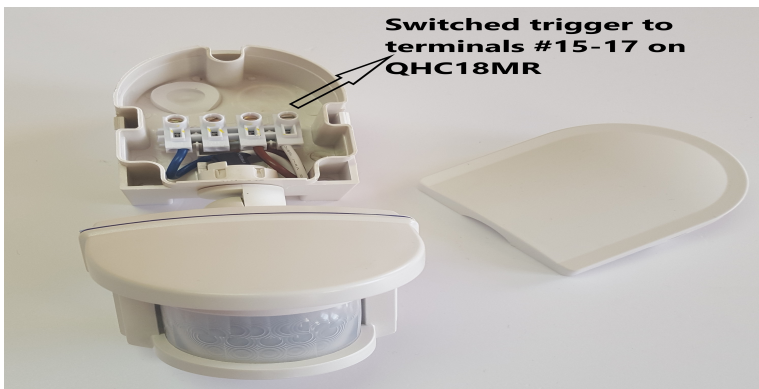

Fig 6

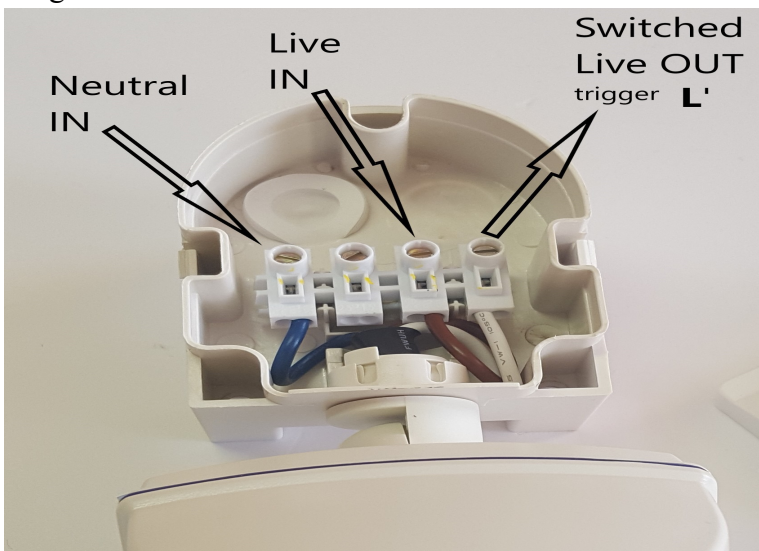

Fig 7

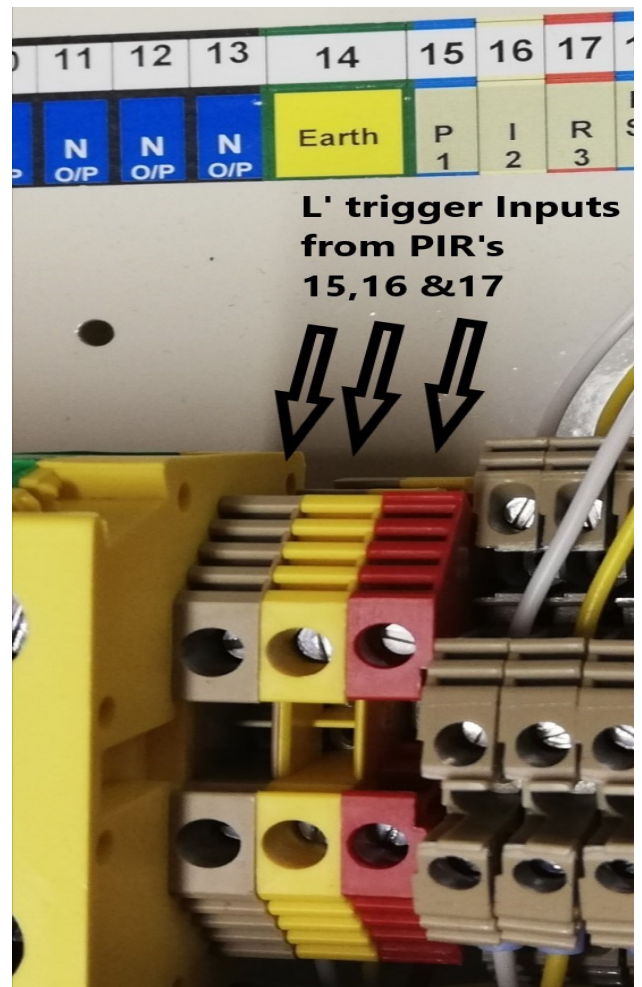

Fig 8

External Switch Connection & Operation

New Timer (15 to 60 minute) function Base H

External switches can be connected to the controller via terminals #18,19 & 20 a+b. This particular terminal is a Double deck terminal. The switch must be a normally open contact switch (NO) and contacts must be voltage free.

When using External Switches – S2 slide switch must be in the ON position (select 1). See fig. 4 Remember there are 3 zones, Blue Yellow & Red. Connect the switch contacts across the input terminals #18,19 or 20 a+b for separate control of each zone. See fig. 9 Only 1 external switch can be connected per zone.

For single external switch operation, a link bar with mount screws can be fitted connecting the 3 input (terminals #18,19 & 20 a) together. In this configuration 1 External Switch will turn ON all 3 zones together. See fig. 10

When the external switch contacts are closed / pushed, this will trigger the controller and turn ON the appropriate zone. The external switch controls the Timer function for each zone.

The Timer functions are pre-programed as follows, note pushes must be **within a 5 second interval !** 1 push for 15mins, 2 pushes for 30mins, 3 pushes for 45 mins & 4 pushes for 60mins.

External switch example, this time use the Link bar to connect across terminals #18,19 & 20. This connection is voltage free so standard signal wire can be used. Connecting the set of terminals on each controller together allows for one External switch to again control several controllers at once.

Fig 9

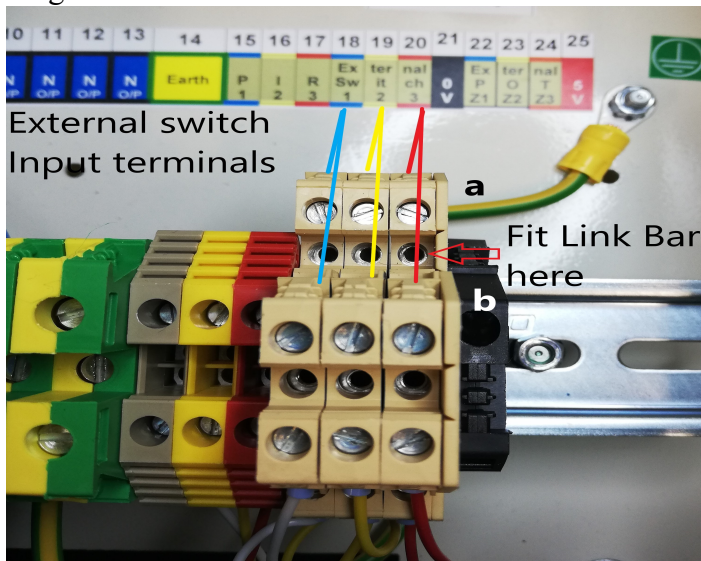

External Switch Input terminals 18,19 & 20

Fig 10

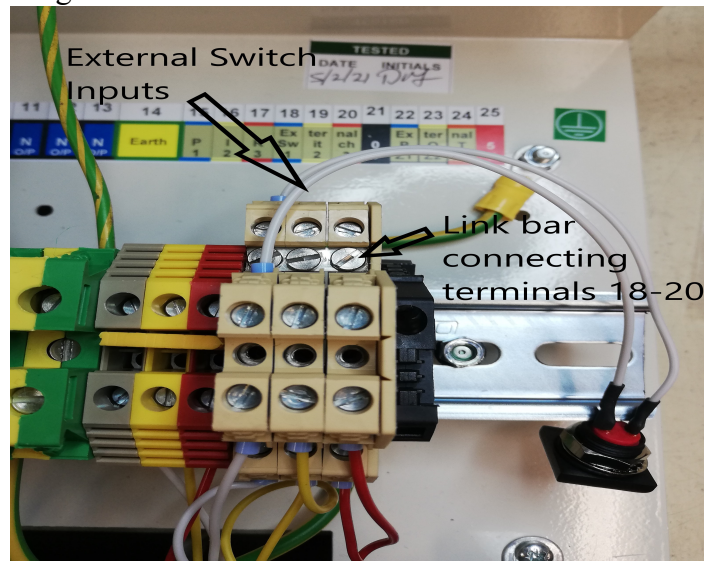

Link bar fitted across the 3 inputs 18,19 & 20 Also shown above with test push switch

Using a PIR or an External switch to control several controllers at once is possible. If all the outputs are required to operate as one output. Use the jumper link in the case of the PIR and the link bar for the External switch.

PIR example, connect a jumper link across terminals #15,16 & 17. This turns the 3 inputs into 1 input. So, one PIR L1 trigger input will now control all 3 outputs. If the same terminals #15,16 & 17 on several other controllers are also connected in the same way using a jumper link. Then run a cable one wire between each controller connecting each set of terminals #15,16 & 17 together. This setup will now allow several controllers to be controlled by one PIR motion detector.

Note important this L' trigger is a live connection and the appropriate wire must be used.

QHVC-S3 Connection & Operation

The purpose of this device is to replace the control dial on the front panel to a more local position close to the operator. This allows the operator to control each zone separately & independently. The QHVC-S3 is a hard wired device using a low voltage +5v DC supply.

The QHVC-S3 is supplied separately and must be pre-ordered when ordering the QHC18M controller. By pre-ordering, the controller will be fitted with the terminal connectors #21 to 25. See fig. 12 Use Alarm type 6 core cable A/6C, use all the coloured wires except the Green wire.

Remove the back plate from the QHVC-S3, there is a connector block which must be used to connect the Alarm cable to the QHC18M controller. The coloured wires should be connected as follows. **Black to terminal #21, Blue to #22, Yellow to #23, Red to #24 & White to #25** see fig's 11 & 12

Note: The QHVC-S3 conversion kit is use to convert a standard controller which had not been pre-ordered and the conversion is done later.

The cable harness provided must replace the one that already exists in the controller. Remove the existing cable harness from the **J9 header** on each of the 3 electronic printed circuit boards and replace with the new QHVC-S3 harness, see fig 5 - **J9 Pot control**. See fig 5

Note: This facility is not available on the standard controllers! This must be pre-ordered.

Fig 11

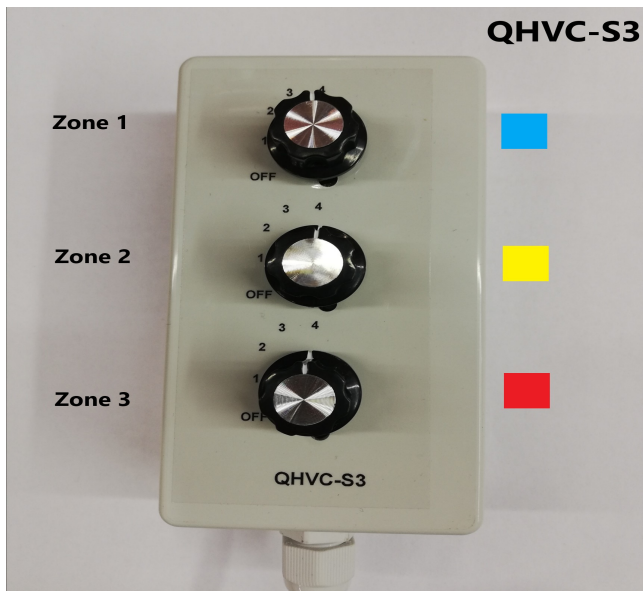

QHVC-S3 illustration showing coloured zones

Fig 12

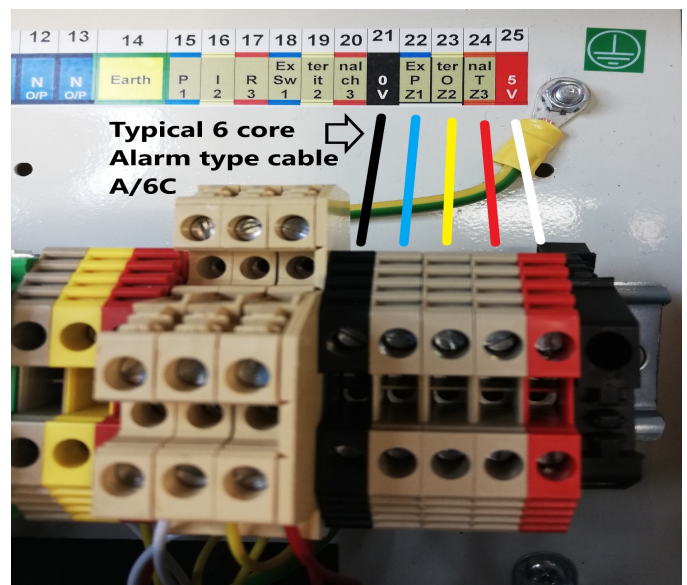

Terminals #21-25 shown fitted for QHVC-S

Over Temperature Protection

There are 3 temperature sensors and 3 LED indicators one for each zone. The LED indicators are located on the front panel marked 1,2 & 3. When an over temperature situation is detected one of these will flash to indicate which zone has over heated. The controller will automatically reduce the power to the affected zone to 50%. (Note this is provided the initial setting is already greater than 50%). With the power reduced the temperature should return to normal working temperature.

If however after 30 minutes this does not happen and the over temperature indicator is still flashing. The controller will automatically shut down (turn OFF) the affected zone, allow the zone to cool down for another 30 minutes. The remaining unaffected zones will continue to work normally. Reset the unit by switching OFF and then back ON using the mains isolation for the controller to recover.

If the over temperature condition persists you are advised to turn off the zone using the appropriate MCB on the front panel and call a qualified electrician to address the problem.

Jumper Link (PIR) & Link Bar (External switch)

Jumper Link and Link Bar & Mnt screws

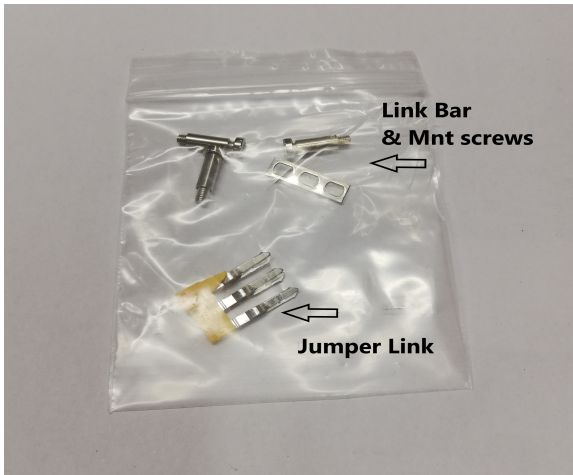

Fig 13

ID conns Red & Yellow with Jumper & Link Bar

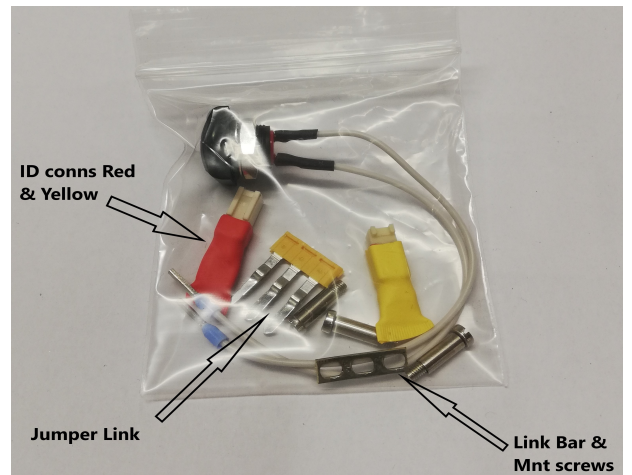

Fig 14

Jumper Link fitted to inputs #15-17 (PIR) & Link Bar fitted to inputs #18-20 (External switch) sold separately.

Note the above kits fig's 13 & 14 are sold separately

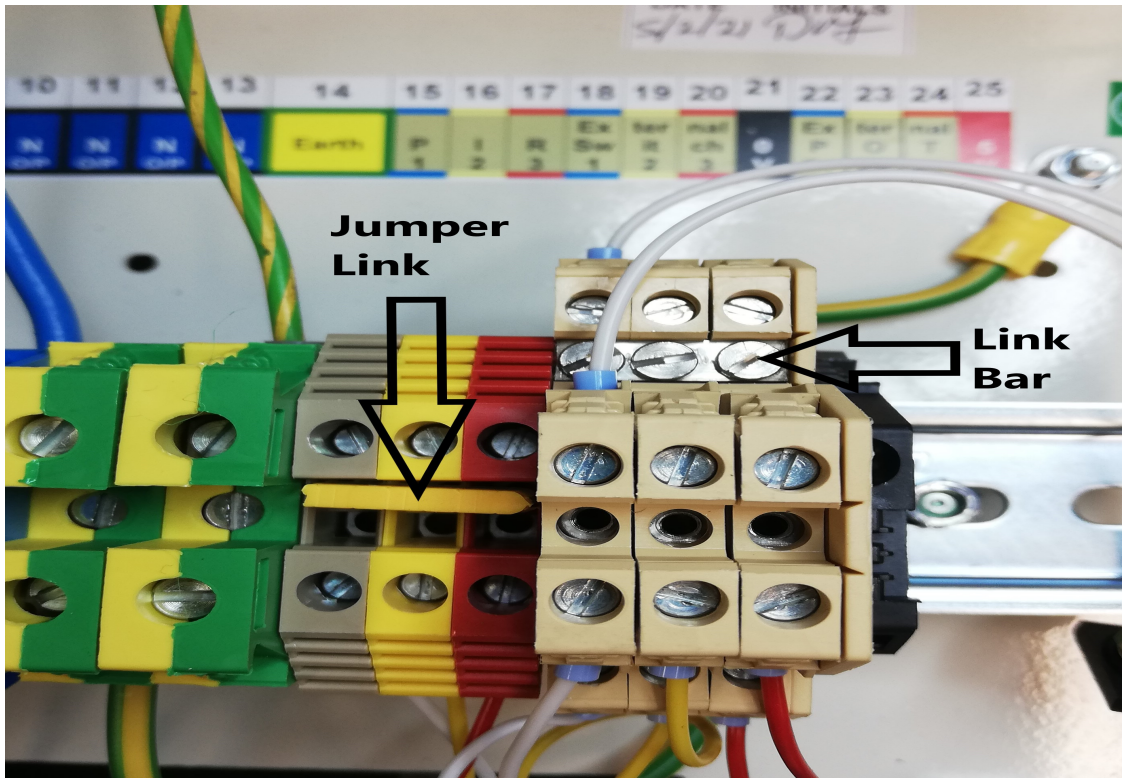

Fig 15

Connecting the Jumper Link to inputs terminals #15-17 allows for one PIR to control the unit. Connecting the Link Bar to inputs terminals #18-20 allows for one external switch to control the unit.

Remember to fit C-Curve MCB circuit breakers & a fused spur for each heater. Also note, single module Residual Current Devices should not be connected.

7-Day programmable timer fitting option

A 7-Day programmable timer can be fitted as an option instead of the PIR. It is important to note that only one or the other can be fitted to the QHC27MR controller **not both**.

S1 & S2 are found on the printed circuit board (PCB) QHPCB-A, See fig 16

Default settings for S1 & S2

Remote **OFF** – S1 Jumper is factory set in the Off position pins 2 & 3,. For Manual operation.

PIR & 7-Day Timer **OFF** - S2 Slide switch is factory set in the Off position “2”. See Fig 16

To set up for a 7-Day programmable timer

S2 Slide switch must be set in the ON position “1”, See Fig 16

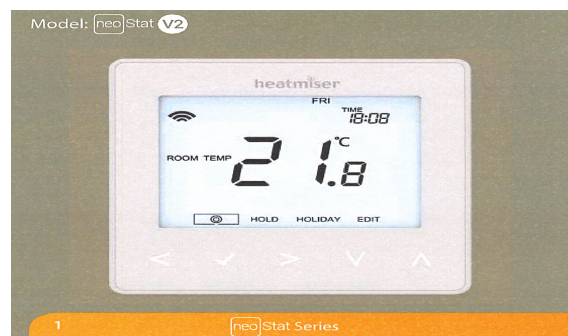
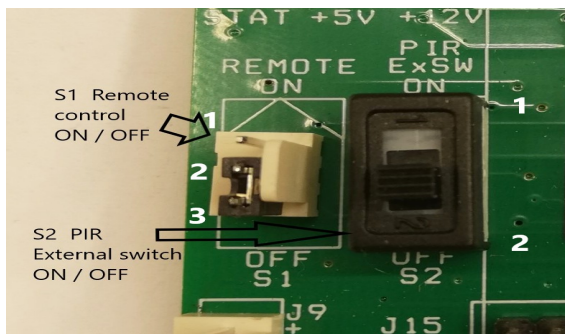

Fig 16 Slide switch S2 OFF position

Fig 17 Typical 7-Day Programmable Timer



Wiring Diagram - neoStat to QHC18M or MR Controllers

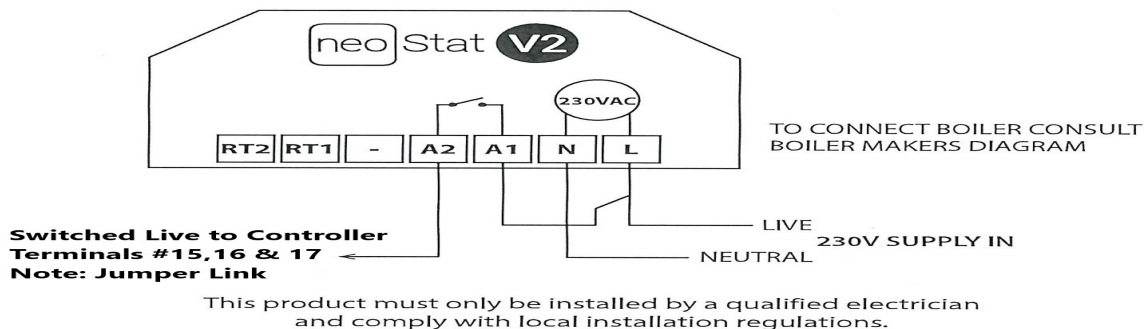

Fig 18 Wiring connection to the QHC27M & MR controller

The switched Live through A2 terminal on the 7-Day timer is connected to terminals #15,16 & 17 on DIN rail connections of the QHC27M & MR controller. Note a Jumper Link must be fitted to terminals #15,16 & 17 in order that the three outputs will operate together as one, See Fig 5,12 & 15.

Once the 7-Day programmable timer is fitted correctly it will now control when the controller will be ON or OFF. See fig 18.

This function can be disabled by simply switching the S2 slide switch back to the OFF position 2 See fig 12.

Wiring diagram for 18-27kW controllers

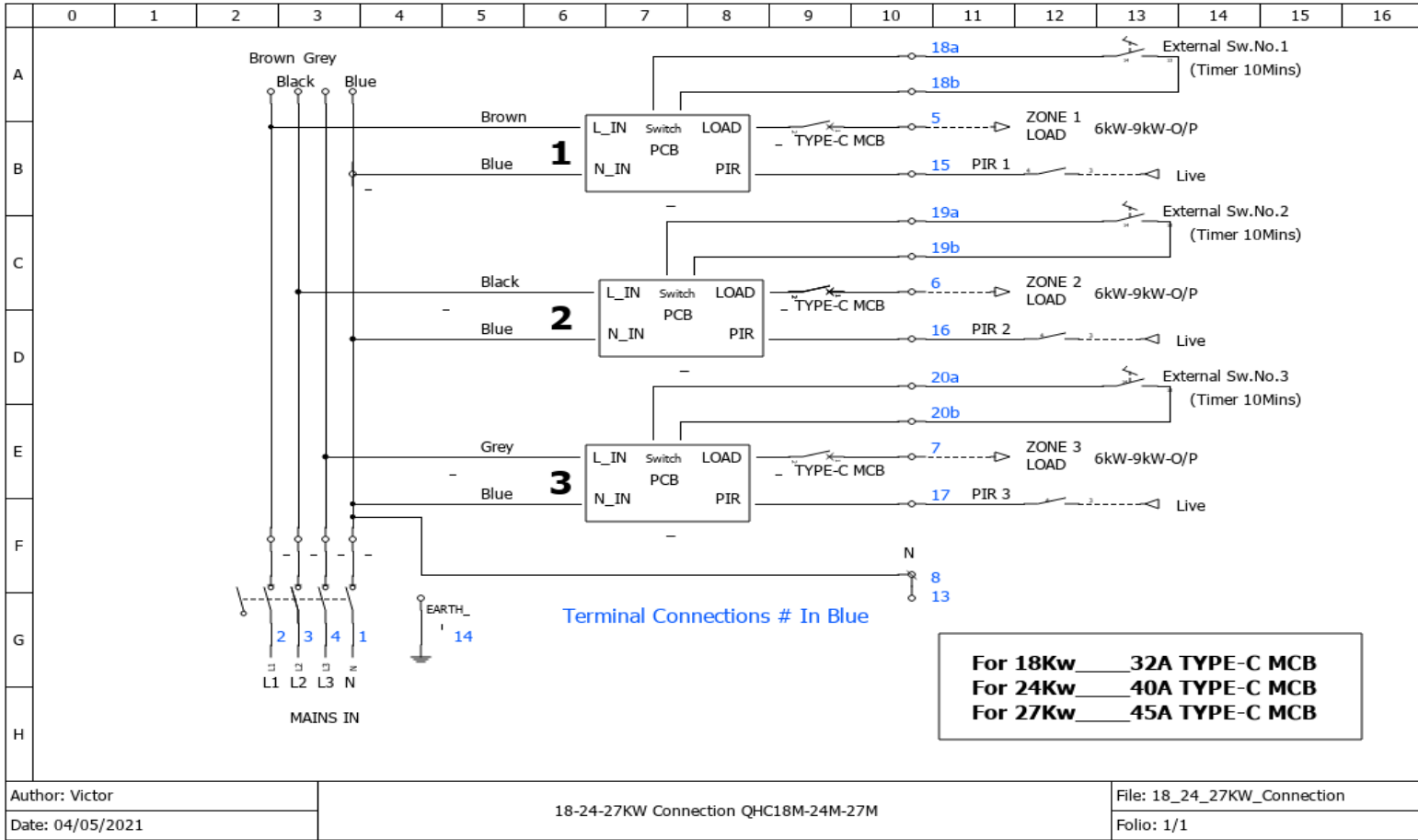

Fig 19

Suggested wiring configuration using an external 7-Day Timer & 4 Pole Contactor switch

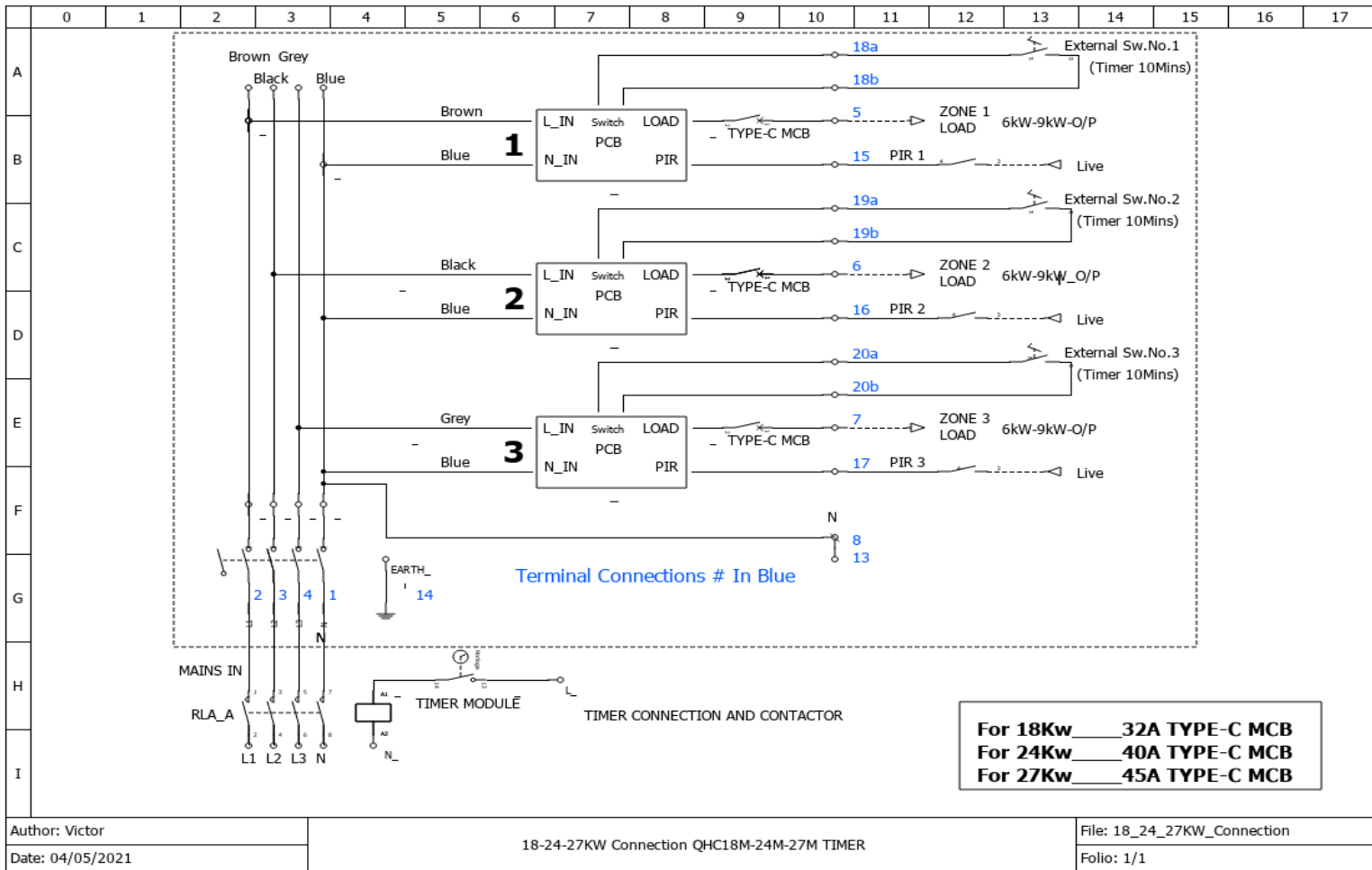

Fig 20

Flickering - J17 Red jumper link

If the user experiences flickering of lights after the system is installed.

The cause is as follows,

- (1) The power control is accomplished by omitting half mains cycles, this is done to ensure no electromagnetic interference.
- (2) On occasions when a half cycle is switched off it can cause a small voltage change on the mains wires which can be seen on some types of lights.

The solution is as follows below

You can move the Red jumper link to positions 2&3 on the header marked J17 on all 3 printed circuit boards QHPCB-A, see fig 21. This limits control levels to 50% & 100% which cannot be seen on any type of light.

The default setting for the Controller is with the Red jumper link in positions 1&2 and should be left in this location for normal operation.

When J17 is set in the default position all four power levels will function as normal.

However, when set in positions 2&3 only power levels 2 & 4 will function.

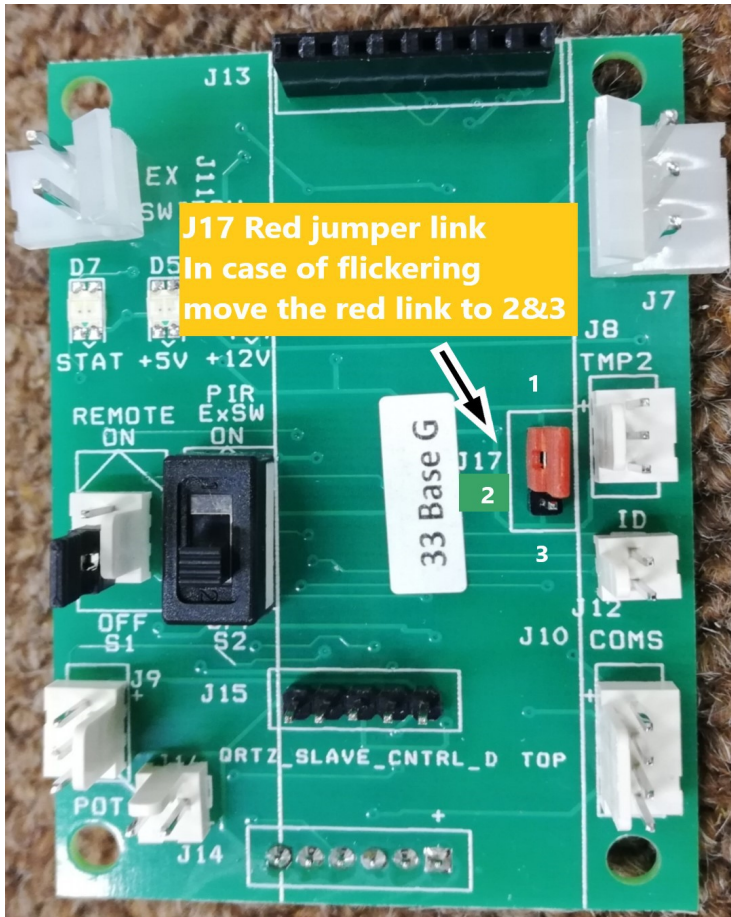

Fig 21 QHPCB-A



QHC18M-3Z
Manual 3 zone



www.factron.ie

Products within this range



18kW 3 phase Manual Heater Controller QHC18M

The QHC18M, QHC24M & QHC27M are manual 3 phase heater control panels with load capacities of 18kW, 24kW & 27kW across 3 channels.

Save up to 60% of your energy costs by using the 4 energy saving levels 1-4.

The controllers are fitted with an Isolation switch for the incoming 3 phase supply and for circuit protection MCB's are fitted on the three channels.

There are additional facilities for a timer function via auxiliary inputs for external switches NO(normally open) to close contacts. There are also inputs for a mains switched (trigger) voltage for use with PIR motion detectors or an external 7-Day programmable timer.

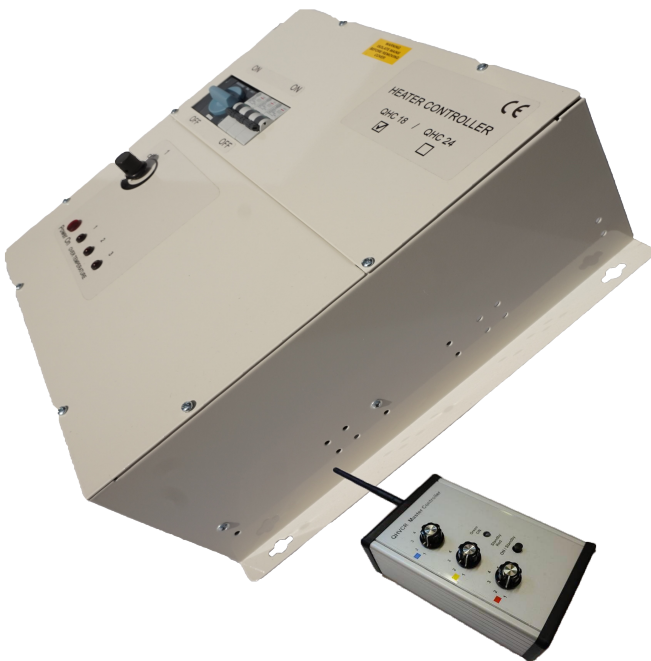

18kW 3 phase RF Heater Controller (receiver) QHC18MR

The QHC18MR, QHC24MR & QHC27MR are remotely controlled 3 phase RF heater control panels with load capacities of 18kW,24kW & 27kW across 3 channels. These controllers can be operated manually or remotely via the selector dial on the front panel. When set in remote mode this device is controlled by the transmitter QHVCR 3 Zone Master controller.

Save up to 60% of your energy costs by using the 4 energy saving levels 1-4.

The controllers are fitted with an Isolation switch for the incoming 3 phase supply and for circuit protection, MCB's are fitted to the three channels. There are additional facilities for a timer function via inputs for external switches NO(normally open) to close contacts. See fig 9 & 10

There are also inputs for a mains switched (trigger) voltage for use with PIR motion detectors or an external 7-Day programmable timer.

Note: The transmitter QHVCR is sold separately & is not included in the price.



12kW 3 phase RF Heater Controller (receiver) QHC12MRE

The QHC12MRE is a wireless RF receiver which controls the power to Infrared heaters up to a load capacity of 12kWatts. This device is paired with the QHVCR 3 Zone remote Master Controller. Any number of these devices can be in a zone as long as they are within the 100 meter transmit range.

3 Phase controller



9kW Single phase RF Heater Controller (receiver) QHC09MRE

The QHC09MRE is a wireless RF receiver which controls the power to Infrared heaters up to a load capacity of 9kWatts. This device is paired with the 3 Zone remote Master Controller QHVCR. Any number of these devices can be in a zone as long as they are within the 100 meter transmit range.

Single phase controller



6kW Single phase RF Heater Controller (receiver) QHC06MRE

The QHC06MRE is a wireless RF receiver which controls the power to Infrared heaters up to a load capacity of 6kWatts. This device is paired with the 3 Zone remote Master Controller QHVCR. Any number of these devices can be in a zone as long as they are within the 100 meter transmit range.

Single phase controller

3 Zone RF Master Controller (transmitter) QHVCr



The QHVCr is a wireless RF transmitter used to control any of our remote heater controllers QHC06MRE, QHC09MRE, QHC12MRE, QHC18MRE, QHC18MR, QHC24MR & QHC27MR receivers.

There are 3 zones Blue, Yellow & Red with five power settings Off to 4 . Setting 1 is the minimum and 4 the highest. This device will control several receivers in each zone provided they are within the Transmit range of 100 meters. This range can be extended to if required.

The unit is battery powered and requires 3 x AAA batteries.



Factron
A BETTER SOLUTION

Unit 12 Ashbourne Ind. Park,
Ashbourne Co.Meath
A84 HY74
Ireland

CE Declaration of Conformity

QHC controllers

(LV Distribution panels) HS code 853710845

Product codes:

QHC06M, QHC06MRE, QHC09MRE, QHC12MRE, QHC18MRE,
QHC18M, QHC18M-3Z, QHC18MR, QHC24M, QHC24M-3Z, QHC24MR
QHC27M, QHC27M-3Z, QHC27MR

Comply with the harmonised standards and provisions of EC-Directives:

2006/95/EC – The Low Voltage Directive
2004/108/EEC – The Electromagnetic Compatibility Directive

We Factron Ltd declare the equipment named above complies with all the applicable essential requirements of the directives.

Signed by : *David Francis* on behalf of FACTRON LTD

Date : 08 / 07 / 2024



**Remember to fit C-Curve MCB circuit breakers & a fused spur for each heater.
Also note, single module Residual Current Devices should not be connected.**

Troubling shooting

- 1) The QHCxxM controller is not working.

Check that the unit is wired correctly and follow the installation procedure on page 1. The neon indicator should be ON to indicate the the Mains is connected correctly.

Then check that the status LED D5, the +5v LED D6 & the +12v LED D7 are all ON green. If the status LED is Red, this indicates that there is a problem with the mains connection to the board.

If the +5v or +12v LEDs are Red this indicates that there is a problem with the processor chip or a power supply problem.

- 2) Check the wiring connections to QHVC-S3 or any external control unit.

If there is a bad contact or a wire incorrectly fitted this could cause a problem ! Ensure that the connections are making proper contact and that all wire are in the correct positions.

- 3) If the controller does not respond to level settings 3 & 4.

Check the for a loose or missing Black connector ref. J8 (TMP2) header on the printed circuit board (PCB).

- 4) If the S1 jumper is in the remote ON position. The QHCxxM (manual) controllers will not operate.

For manual operation ensure that the jumper is in the OFF position see fig 4 IMPORTANT note on page 3.

- 5) If the S2 slide switch is in the ON position. The QHC06M or 09M controllers will appear to not work.

You must either ensure that an external device is connected to position #1 on the strip connector. The external devices are a PIR sensor or a 7-Day programmable timer. If these are not connected when the S2 slide switch is in the ON position the controller will not work. If there are no external devices connected then make sure that the S2 slide switch is in the OFF position.

The only device which must be connected is the QHVC-S1 external control unit, refer to page 2 for QHVC-S1 connection to the QHC06M or 09M controller.

- 6) Circuit Breaker MCB keeps tripping when the heaters are turned ON ! This is normally caused by IN RUSH Current, a C-Curve MCB must be used. A common fault is to use B-Curve but these will always fail. Replace with a C-Curve and the problem should be fixed. In some situations on very cold mornings, the C-Curve MCBs might trip during the initial switch ON. To avoid this, the best oprion is to upgrade the MCBs to D-Curve version.

Also, if using RCBO's again C-Curve must be used. In some case's you will have to use the double module version of the RCBO.

The RCBO's are more sensitive & D-curve may have to be used instead !

Supply voltage : Three phase 415V AC 50/60 Hz

All O/P's with Soft start

Max. Load capacity: 27 kilo Watts * (Load must be balanced across all 3 outputs max 9 kW each)

Over Temperature Protection: On each O/P - Led indicators 1,2 & 3

Mains I/P :	Neutral (Blue)	terminal #1
	Live 1 (Brown)	terminal #2
	Live 2 (Black)	terminal #3
	Live 3 (Grey)	terminal #4
Mains O/P :	Switched Live 1 (Brown)	terminal #5
Soft start	Switched Live 2 (Black)	terminal #6
	Switched Live 3 (Grey)	terminal #7
	Neutral return out (Blue)	terminal #8-13
	Earth out (Green/Yellow)	terminal #14
PIR I/P :	Live trigger input Zone 1	terminal #15
Auxiliary	Live trigger input Zone 2	terminal #16
Device	Live trigger input Zone 3	terminal #17
Ext. Sw. I/P :	Ext. SW1 Zone 1	terminal #18 a+b contacts Normally Open
Auxiliary	Ext. SW2 Zone 2	terminal #19 a+b contacts Normally Open
Device	Ext. SW3 Zone 3	terminal #20 a+b contacts Normally Open
QHVC-S I/P :	0V	terminal #21
Auxiliary	Zone 1	terminal #22
Device	Zone 2	terminal #23
Optional	Zone 3	terminal #24
	5V	terminal #25
IP Rating:	IP53	
Dimensions :	350mm x 330mm x 150mm	Note : Terminal connections are the same
Weights :	QHC27M – 12 Kg	for both the QHC27M
		& QHC27MR controllers.

Manufactured in Ireland
Country of Origin Rep. of Ireland



Tel. 00 353 1 8352718 Email: paul@factron.ie dave@factron.ie
Website: www.factron.ie

Factron Ltd. Unit 12 Ashbourne Ind. Park, Ashbourne, Co.Meath , A84 HY74, Ireland