



# QHC18MRE 18kW RF Heater Controller (Receiver)

QHC18MRE



QHC18MRE

**3 Phase 415v / 3 Channel / Soft Start / RF**

**Remote Operation**

# Quick Start for QHC18MRE 18kW Heater Controller (receiver)



1	2	3	4	5	6	7	7	7	8	8	8	9	9	9	10	10	10	11
Earth IN	Timer Input	L1 IN	L2 IN	L3 IN	N IN	N Out	N Out	N Out	L1 OUT	L1 OUT	L1 OUT	L2 OUT	L2 OUT	L2 OUT	L3 OUT	L3 OUT	L3 OUT	Earth Out

Fig 1

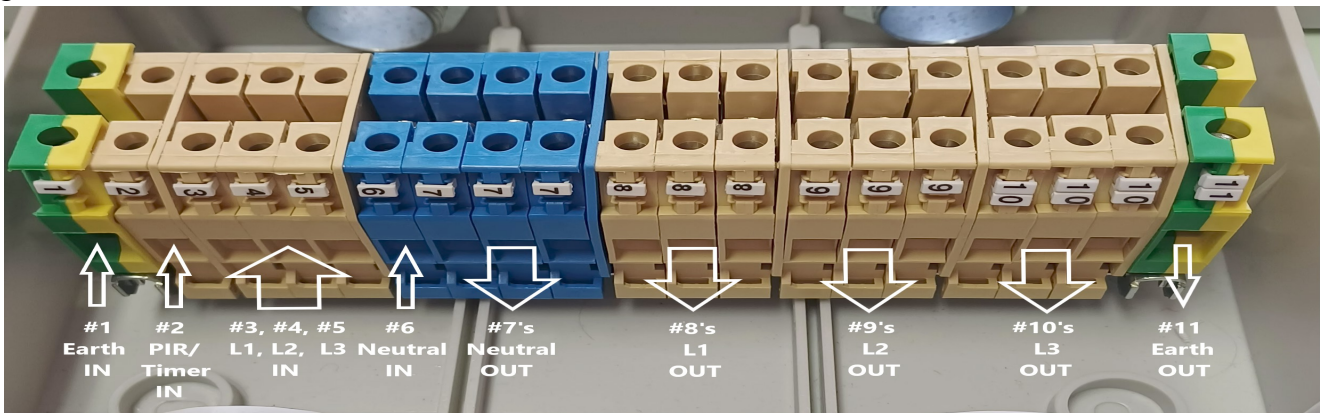
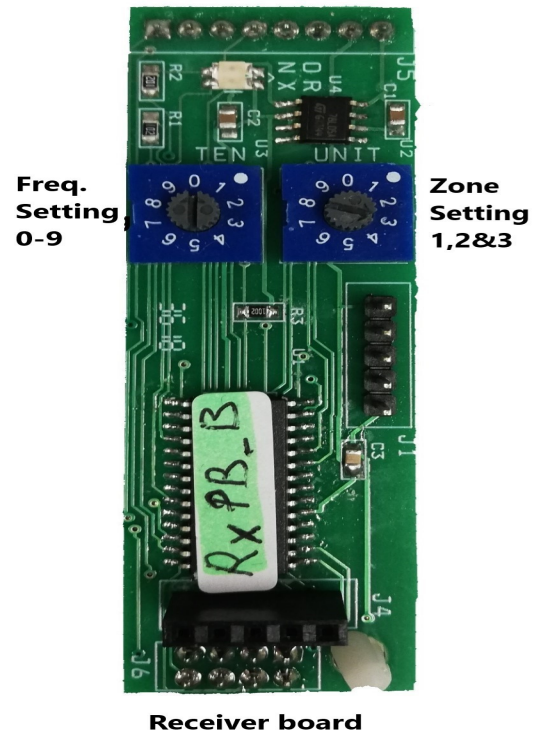

Fig 2

- 1) Remember isolate the Mains before removing the cover. Remove the cover by removing the 4 screws from the terminal box lid.
- 2) Use the two cable glands to bring the Mains cables into and out of the controller base .
- 3) Connect Mains IN - L1 brown to #3, L2 black to #4 and L3 grey to #5 wires to terminals marked L1 IN (3), L2 IN IN (4) and L3 IN (5). See Fig's 1 & 2  
Then connect Neutral IN and Earth IN, N in blue to #6 and Earth in green/yellow to #1.
- 4) Connect the Infrared Heater to load outputs – L1 OUT from #8 brown , L2 OUT from #9 black, L3 OUT from #10 grey. The Neutral Out from #7 blue and the Earth OUT from #11 green/yellow. See Fig's 1 & 2
- 5) The trigger\* L' from the 7-Day Programmable Timer is connected to Timer Input #2 white (2).  
Note: \*a motion sensor (PIR) can be connected to this input instead of a Timer. See Fig's 1 & 2
- 6) When all connections are complete and connected correctly, check once again that the wiring is correct as per 3) & 4). Then replace the cover and tighten the fixing screws.
- 7) Turn ON or reconnect the Mains Power to the controller. The red neon lamp on the LHS will illuminate to indicate that the unit is **LIVE**.  
The controller is now ready to be controlled by the wireless remote unit **QHVC**R. See instructions for QHVC R operation, page 2 follow steps 8) to 14).

## QHVCRC 3 Zone RF Master Controller (transmitter)



- 8) There are three control dials Blue, Yellow & Red one for each zone. The QHC18MRE units are preset to operate in one of these zones. The QHC18MRE unit once preset will only operate in that designated zone. The factory setting is 1, this will be the Blue control dial.
- 9) Turn ON the QHVCRC unit by pressing the ON/Standby button on the front panel. The Led indicator will flash orange – green – orange – green and remain Green to indicate that the unit is ready.
- 10) The QHC18MRE unit is preset as a Blue zone (1). Turn the Blue control dial to position **1**. The heaters connected to the QHC18MRE units will come ON at the minimum setting 33%. Continue to turn the Blue control dial through position 2 to 4 until you reach the desired setting. Settings are **OFF = 0%**, **1 = 33%**, **2 = 50%**, **3 = 66%** & **4 = 100%**.
- 11) QHC18MRE units which are preset to Yellow & Red zones are controlled by the Yellow & Red control dials respectively and will operate as above in 10).
- 12) The QHVCRC unit is powered by 3 x AAA battery's. So, the unit will automatically go into standby mode if the unit is inactive for more than 30 seconds. When the unit goes into standby mode all the QHC18MRE units will remain unchanged at the settings they were set at. The heaters will remain ON.
- 13) To change a setting just press the ON/Standby button and proceed as described in 9) & 10). However, while the QHVCRC unit is ON, you can turn OFF all the heaters by pressing the ON/Standby button. This is indicated by the Led indicator flashing Red.
- 14) The previous settings will be remembered and will be restored when you press the ON/Stand by button again.  
Please note that the QHVCRC remote Master Controller can control any number of QHC06MR, QHC12MRE & QHC18MRE controllers as long as they are within range, up to 100 meters \*

(see specification sheet for the QHVCRC unit)

# Pairing (programming) Devices QHVCr & QHCxxMRE

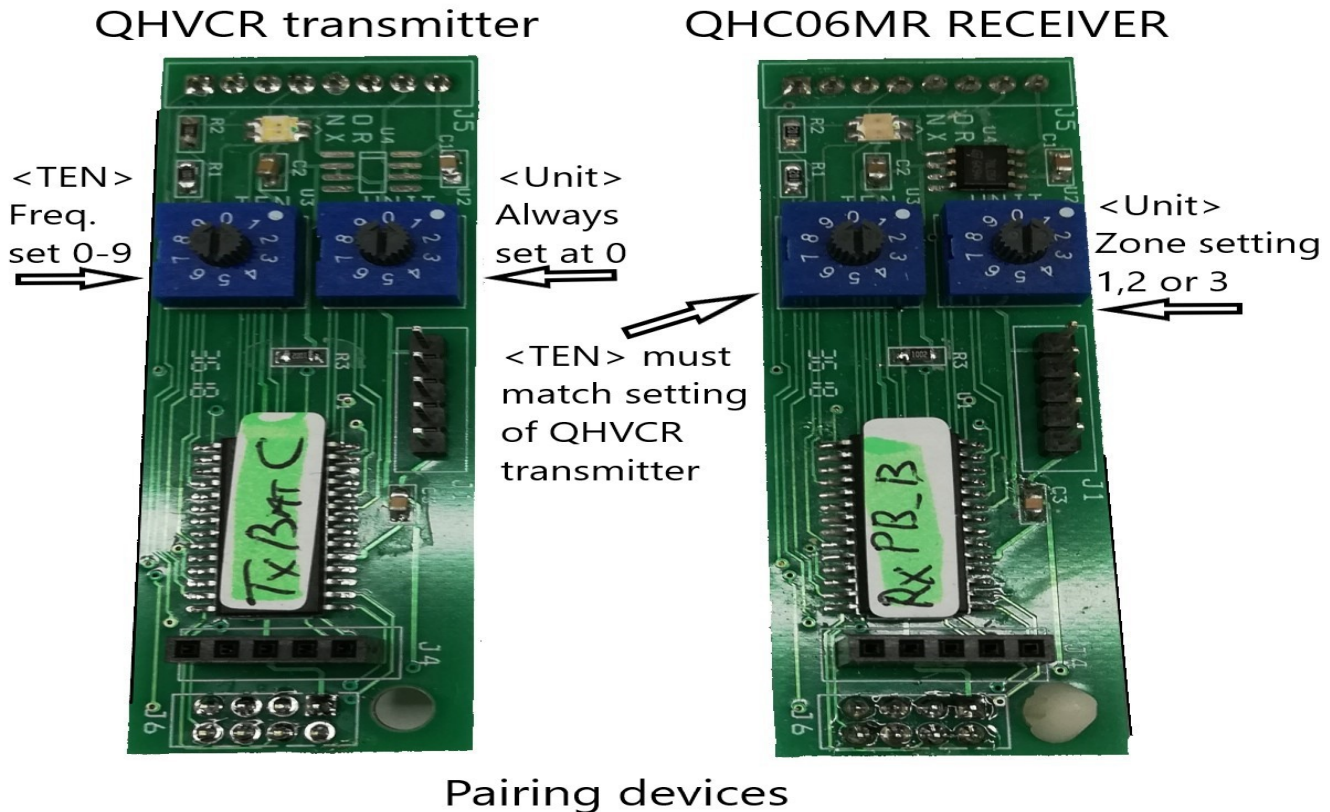

## Pairing (programming) devices QHVCR (transmitter) and QHCxxMRE (receivers).

- 1) The Left Hand Side rotary switches (TEN) on both boards must be set the same. The LHS switch (TEN) is used to set the RF frequency the setting must match on both boards. There are **10** possible frequencies that can be selected **0-9**. If the settings on the LHS switch (TEN) do not match the devices will fail to operate.

Designating the transmitter and receiver. Both the left rotary switches are set at **0**, this ensures that the transmitter marked **0** will communicate with the receiver marked **0**. Setting the left rotary switch to **1**, so the transmitter marked **1** will communicate with a receiver also marked **1**.

If the transmitter and receiver are not paired correctly they will not communicate and therefore will not operate; transmitter marked **0** will **not communicate** with a receiver marked **1**.

Remember a transmitter can be set at any number between **0-9** & the receiver must be matched correctly.

- 2) The Right Hand Side rotary switches (UNIT) are for setting the device to operate in a set zone. There are 3 possible zones that the controller can be set to. The RHS switch (UNIT) should be set to 1,2 or 3.

**Blue** Zone 1 operation set RHS switch (UNIT) to **1**

**Yellow** Zone 2 operation set RHS switch (UNIT) to **2**

**Red** Zone 3 operation set RHS switch (UNIT) to **3**

# PIR motion detector (QHPIR) fitting



PIR motion detectors are passive infrared sensors an electronic device which is triggered by infrared light from the movement of objects in it's field of view. A PIR can be connected to a QHC18MRE controller.

This will enable the controller to turn ON the heaters only when the presence of a person or people are detected by the PIR.

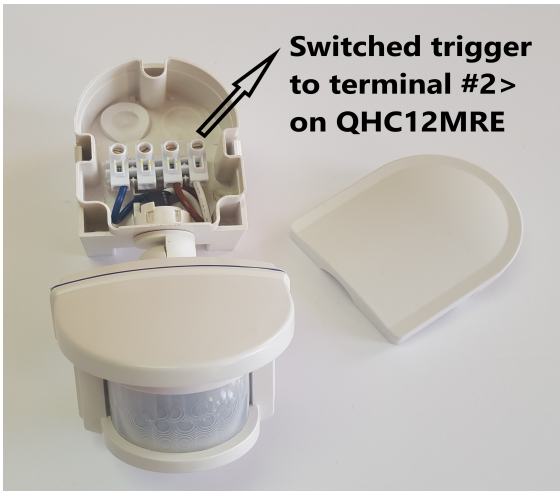

The angle of the PIR and the viewing width of the lens will have to be adjusted to ensure the detection area is that which is required. Full lens width will have a large detection area. For a smaller area the lens narrow the lens using the lens mask.

Setting the Lens width correctly is crucial, if this is set incorrectly the PIR could be continuously be ON. This can cause the heaters to remain ON too.

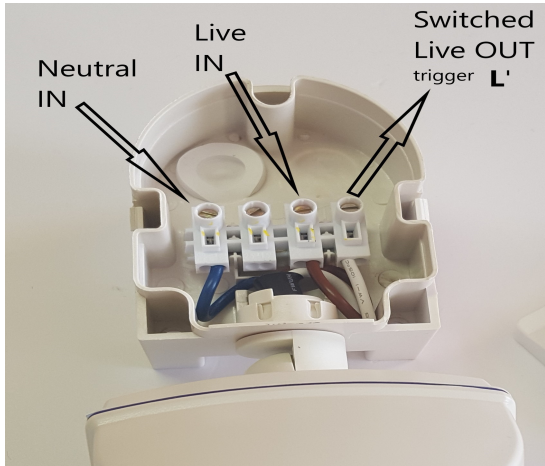

Connect the switched Live trigger L' to terminal #2 PIR Input on the QHC18MRE controller.

The switched Live OUT to the QHC18MRE controller is a Live 240V feed, this is only used as a signal Input to the controller.

Note: a PIR should not be located directly in front of an Infrared heater. The Infrared light emitted from the heater will keep the PIR permanently triggered and the motion detector will fail.

# 7-Day programmable timer fitting option

A 7-Day programmable timer & a PIR can be fitted as an option. It is important to note that only one or the other can be fitted to the QHC18MRE controller but **not both**.

**S1 & S2** are found on the printed circuit board (PCB) QHPCB-A, See fig 3

## Default settings for S1 & S2

Remote **OFF** – **S1** Jumper is factory set in the Off position pins 2 & 3,. For Manual operation.

PIR & 7-Day Timer **OFF** - **S2** Slide switch is factory set in the Off position “ 2”. See Fig 3

## To set up for a 7-Day programmable timer

S2 Slide switch must be set in the ON position “1”, See Fig 3

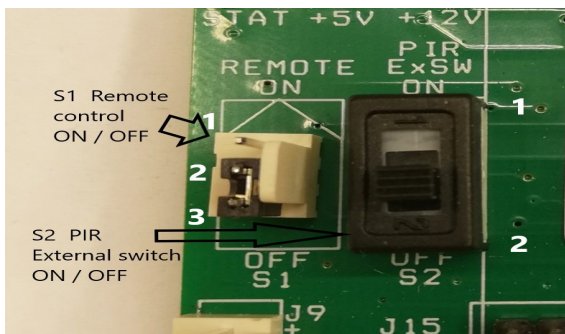

Fig 3 Slide switch S2 OFF position



Fig 4 Typical 7-Day Programmable Timer



## Wiring Diagram - neoStat to QHC12MRE controller

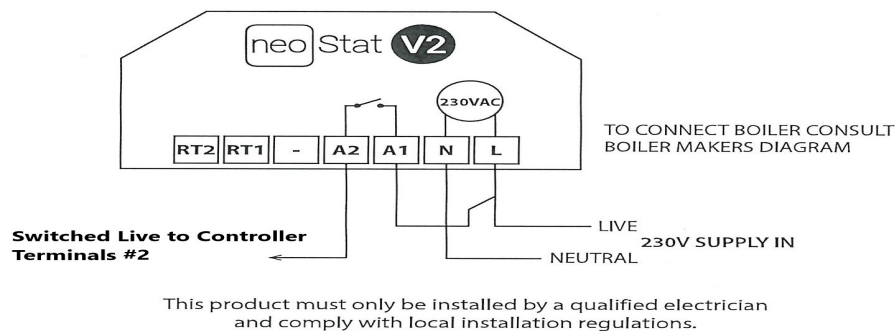

29

neoStat Series

Fig 5 Wiring connection to the QHC18MRE controller

The switched Live trigger (**L**) through A2 terminal on the 7-Day timer is connected to terminal #2 on the DIN rail terminal block of the QHC12MRE controller See Fig 1,2 & 5.

Once the 7-Day programmable timer is fitted correctly it will now control when the controller will be ON or OFF.

This function can be disabled by simply switching the S2 slide switch back to the OFF position 2 See Fig 3

# Expandable heating system using a QHVCR & multiple QHC06MRE, QHC12MRE & QHC18MRE controllers.

Using the remote 3 zone QHVCR controller the area being heated can be zoned into three area's Blue, Yellow & Red. Each zone can be controlled separately, this includes setting each zone at a different level. There are 5 power level settings > Off - 1 (33%) - 2 (50%) - 3 (66%) - 4 (100%).

Any combination of our QHC controllers can be used in the proposed zoned layout below. There are 6kW QHC06MR, 12kW QHC12MRE & 18kW QHC18MRE controllers available to be used depending on the over all number of heaters required.

 Blue zone 6kW controller set a (0) > 0-1



Blue zone has 3 x 2kW heaters Total 6Kw

 Yellow zone 12kW controller set as (0) > 0-2



Yellow zone has x 4.5kW heaters Total 9kW

 Red zone 18kW controller set as (0) > 0-3



Red zone has 1 x 12kW heater Total 12kW

Remote 3 zone QHVCR controller set as an (0) > 0

This configuration allows the heaters in the Blue zone be controlled by the 1<sup>st</sup> dial on the remote control, setting levels at Off to 4. The Yellow zone is controlled by the 2<sup>nd</sup> dial & the Red zone is controlled by the 3<sup>rd</sup> dial.

For larger installations multiple controllers and heaters can be added to each zone where required.



**It is recommended that each heater should be fused with a spur. Each controller should have a C-curve MCB circuit breaker and the whole installation must have an Isolation switch.**

# Wiring diagrams

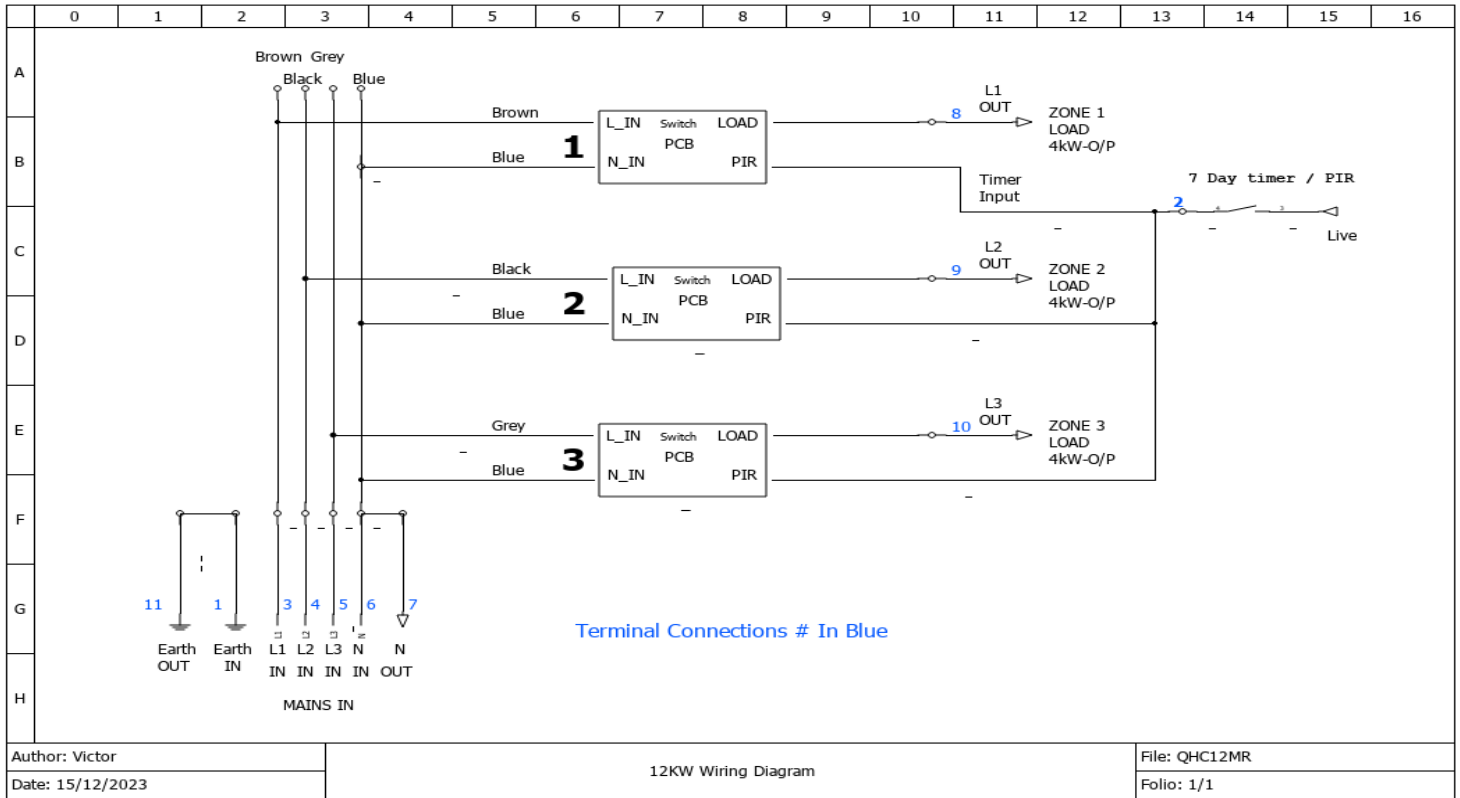

## Wiring diagram for 3 phase 18kW QHC18MRE controller. (this is the same as a 12kW)

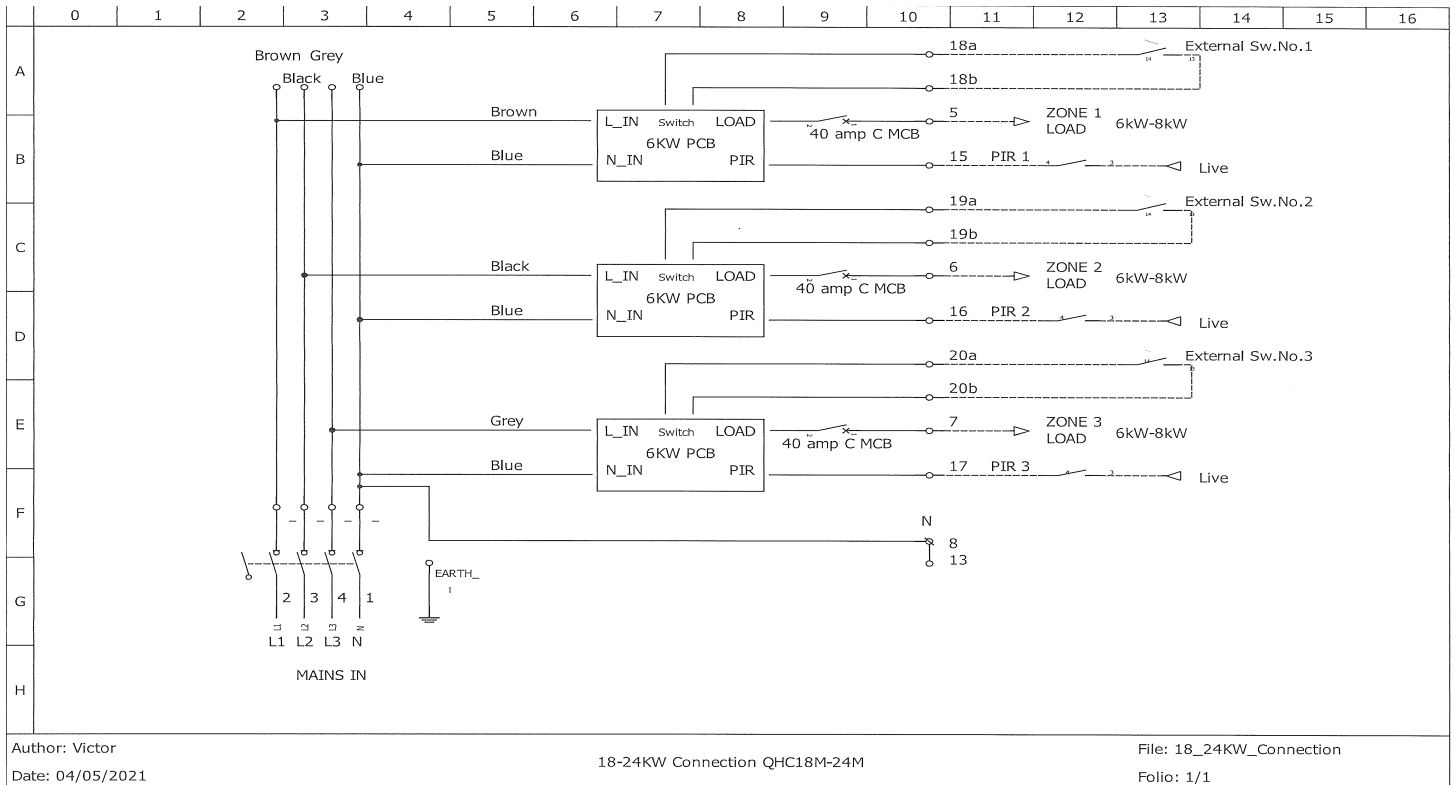

Wiring diagram for 3 phase 18kW & 24kW controllers.

**See page 13 for protection devices.**

# Flickering - J17 Red jumper link

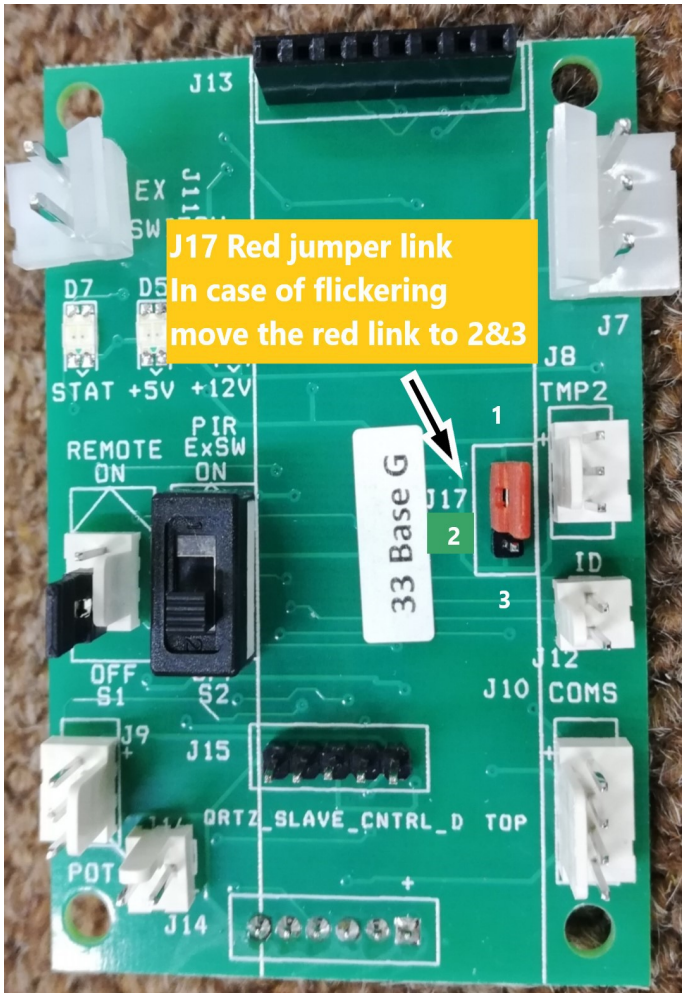

If the user experiences flickering of lights after the system is installed.

The cause is as follows,

(1) The power control is accomplished by omitting half mains cycles, this is done to ensure no electromagnetic interference.

(2) On occasions when a half cycle is switched off it can cause a small voltage change on the mains wires which can be seen on some types of lights.

The solution is as follows below

You can move the Red jumper link to positions 2&3 on the header marked J17 on all 3 printed circuit boards QHPCB-A, see fig 6. This limits control levels to 50% & 100% which cannot be seen on any type of light.

The default setting for the Controller is with the Red jumper link in positions 1&2 and should be left in this location for normal operation.

Fig 6 QHPCB-A

When J17 is set in the default position all four power levels will function as normal. However, when set in positions 2 & 4 will function.



**QHC18M-3Z**  
**Manual 3 zone**



[www.factron.ie](http://www.factron.ie)

# Troubling shooting

- 1) The QHC18MRE (receiver) is not working.

Check that the unit is wired correctly and follow the installation procedure on page 1. The neon indicator should be ON to indicate the the Mains is connected correctly.

Then check that the status LED D5, the +5v LED D6 & the +12v LED D7 are all ON green. If the status LED is Red, this indicates that there is a problem with the mains connection to the board.

If the +5v or +12v LEDs are Red this indicates that there is a problem with the processor chip or a power supply problem.

- 2) There is no communication between the QHC18MRE & QHVCR

The units may not be paired correctly. First determine what frequency the QHVCR is set at. The setting is marked at the back of the unit. If it's marked **(0)** you must check to see if the QHC18MRE is also set the same and is also marked **(0)**. If they are different then the controller QHC18MRE will not work.

If needed you can reset the controller by following the Pairing instructions on page 3.

- 3) Paired transmitter QHVCR & receiver QHC18MRE still won't communicate even when they are both set the same. The small antenna RF PCB could be the problem. Check if the small LED flashes Red when the transmitter QHVCR is turn ON & OFF. The communication is good between the two units when the LED flashes Red. Otherwise if the LED remains ON Green then the RF PCB is faulty and needs to be replaced.

However, if the RF PCB is working and the LED flashes Red but the controller QHC18MRE is still not working. The cable connection between the RF PCB and the Antenna could be faulty and may need to be replaced.

- 4) Yellow zone is not working !

The problem could be the receiver is set as a blue zone or red zone. If this is the case all you have to do is re-set the right hand rotary switch to position 2, see page 3

- 5) Circuit Breaker MCB keeps tripping when the heaters are turned ON !  
Ensure that the MCB is a Type C where there are likely to be surges. A common fault is to use Type B but these will always fail. Replace with Type C and the problem should be fixed.

- 6) If the controller does not respond to power levels 3 & 4.

Check for a loose or missing Black connector ref. J8 (TMP2) header on the printed circuit board (PCB).

# Products within this range



## 18kW 3 phase Manual Heater Controller QHC18M

The QHC18M, QHC24M & QHC27M are manual 3 phase heater control panels with load capacities of 18kW, 24kW & 27kW across 3 channels.

Save up to 60% of your energy costs by using the 4 energy saving levels 1-4.

The controllers are fitted with an Isolation switch for the incoming 3 phase supply and for circuit protection MCB's are fitted on the three channels.

There are additional facilities for a timer function via auxiliary inputs for external switches NO(normally open) to close contacts.

There are also inputs for a mains switched (trigger) voltage for use with PIR motion detectors or an external 7-Day programmable timer.

## 18kW 3 phase RF Heater Controller (receiver) QHC18MR

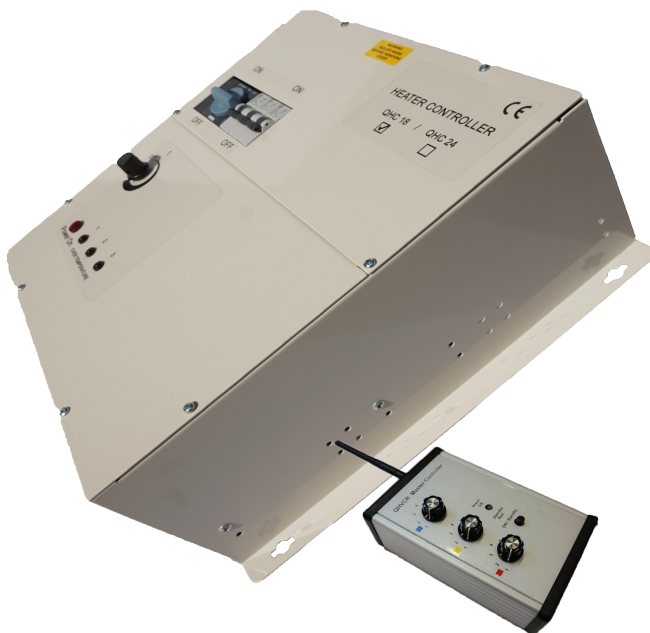

The QHC18MR, QHC24MR & QHC27MR are remotely controlled 3 phase RF heater control panels with load capacities of 18kW, 24kW & 27kW across 3 channels. These controllers can be operated manually or remotely via the selector dial on the front panel. When set in remote mode this device is controlled by the transmitter QHVCR 3 Zone Master controller.

Save up to 60% of your energy costs by using the 4 energy saving levels 1-4.

The controllers are fitted with an Isolation switch for the incoming 3 phase supply and for circuit protection, MCB's are fitted to the three channels. There are additional facilities for a timer function

via inputs for external switches NO(normally open) to close contacts. See fig 9 & 10

There are also inputs for a mains switched (trigger) voltage for use with PIR motion detectors or an external 7-Day programmable timer.

Note: The transmitter QHVCR is sold separately & is not included in the price of the QHC18MR.



**12kW Three phase RF Heater Controller (receiver)  
QHC12MRE**

The QHC12MRE is a wireless RF receiver which controls the power to the infrared heaters up to a load capacity of 12kWatts. This device is paired with the 3 Zone remote Master Controller QHVCR. Any number of these devices can be in a zone as long as they are within the 100 meter transmit range.

Three phase controller

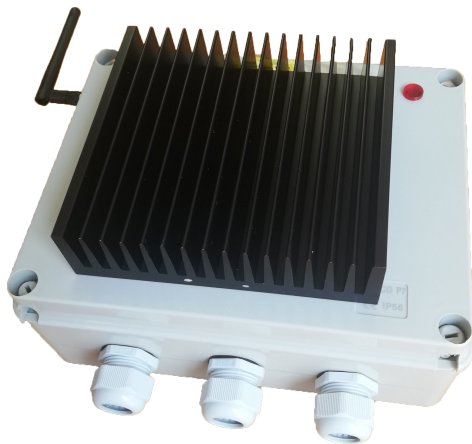

**9kW Single phase RF Heater Controller (receiver)  
QHC09MRE**

The QHC09MRE is a wireless RF receiver which controls the power to Infrared heaters up to a load capacity of 9kWatts. This device is paired with the 3 Zone remote Master Controller QHVCR. Any number of these devices can be in a zone as long as they are within the 100 meter transmit range.

Single phase controller



### **6kW Single phase RF Heater Controller (receiver) QHC06MRE**

The QHC06MRE is a wireless RF receiver which controls the power to Infrared heaters up to a load capacity of 6kWatts. This device is paired with the 3 Zone remote Master Controller QHVCR. Any number of these devices can be in a zone as long as they are within the 100 meter transmit range.

Single phase controller



### **3 Zone RF Master Controller (transmitter) QHVCR**

The QHVCR is a wireless RF transmitter used to control any of our remote heater controllers QHC06MRE, QHC09MRE, QHC12MRE, QHC18MRE, QHC18MR, QHC24MR & QHC27MR receivers.

There are 3 zones Blue, Yellow & Red with five power settings Off to 4. Setting 1 is the minimum and 4 the highest. This device will control several receivers in each zone provided they are within the Transmit range of 100 meters. This range can be extended to if required.

This unit is battery powered and requires 3 x AAA batteries & comes in a wall mounted version which is supplied as standard.

**Remember to fit 32 amp C-curve MCB circuit breakers.  
Also note, single module RCBO's should not be connected, see page 13.**

**Important only a qualified electrician can install these device's.**

# Notes

## Recommended protection devices which can be used with this QHC controller

C-curve double module RCBO's should be used below

Product data sheet  
AD982J

:hager

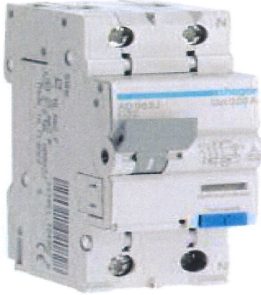

RCBO 1P+N 6kA C-32A 30mA A Class

AD982J

Technical Properties	
Rating current 30°C	32 A
Number of poles	2 P
Curve	C
Number of modules	2
Rated operational voltage Ue	240 V
Frequency	50 Hz
Height of installed product	83 mm
Depth of installed product	68 mm
Residual current type	A
Standard text	EN 61009-1

C-curve single module MCB's should be used below

Product data sheet  
MU132A

:hager



MCB 1P 6kA C-32A 1M

MU132A

Technical Properties	
Rating current 30°C	32 A
Number of poles	1 P
Curve	C
Number of modules	1
Rated operational voltage Ue	230 / 400 V
Frequency	50/60 Hz
Height of installed product	83 mm
Depth of installed product	70 mm
Standard text	IEC 60898-1



**Factron**  
A BETTER SOLUTION

Unit 12 Ashbourne Ind. Park,  
Ashbourne Co.Meath  
A84 HY74  
Ireland

## CE Declaration of Conformity

### **QHC controllers**

**(LV Distribution panels) HS code 853710845**

Product codes:

QHC06M, QHC06MRE, QHC09MRE, QHC12MRE, QHC18MRE,  
QHC18M, QHC18M-3Z, QHC18MR, QHC24M, QHC24M-3Z, QHC24MR  
QHC27M, QHC27M-3Z, QHC27MR

Comply with the harmonised standards and provisions of EC-Directives:

2006/95/EC – The Low Voltage Directive  
2004/108/EEC – The Electromagnetic Compatibility Directive

We Factron Ltd declare the equipment named above complies with all the applicable essential requirements of the directives.

Signed by : *David Francis* on behalf of FACTRON LTD

Date : 08 / 07 / 2024



**Supply voltage : 3 phase 415V AC 50 Hz**

**Max. Load capacity : 18 kilo Watt**

<b>Input :</b>	<b>Earth in (Grn/Yel)</b>	<b>terminal #1</b>
	<b>L1 (Brown)</b>	<b>terminal #3</b>
	<b>L2 (Black)</b>	<b>terminal #4</b>
	<b>L3 (Grey)</b>	<b>terminal #5</b>
	<b>Neutral in (Blue)</b>	<b>terminal #6</b>
<b>Aux Input :</b>	<b>Timer or PIR input trigger (White)</b>	<b>terminal #2</b>
<b>Output :</b>	<b>Neutral out (Blue)</b>	<b>terminal #7</b>
	<b>Switched L1 out (Brown)</b>	<b>terminal #8</b>
	<b>Switched L2 out (Black)</b>	<b>terminal #9</b>
	<b>Switched L3 out (Grey)</b>	<b>terminal #10</b>
	<b>Earth out (Grn/Yel)</b>	<b>terminal #11</b>

**Transmission: RF** 433mHz

**Range : Standard Antenna** 100 meters \*(Line of sight)  
**Extended Antenna** 200 meters \*(Line of sight)

**IP Rating: IP56**

**Dimensions : 500mm x 400mm x 170mm**

**Weight : 5.6 Kgs**

**Notes: C-curve MCB circuit breakers must be used when installing this product.  
It is recommended that heaters connected to this controller should be fused  
individually with a fused spur.**



**Factron**  
A BETTER SOLUTION

**Tel. 00 353 1 8352718 Email: [dave@factron.ie](mailto:dave@factron.ie)**

**Website: [www.factron.ie](http://www.factron.ie)**